

Polished Weld Crosses

Crosses - B9WWWW

Tube OD	Dimensions		Wall Thickness	Polished ID/OD	Polished ID/OD
	A	B		304 Stainless Steel Part #	316L Stainless Steel Part #
1½"	3.312"	1.656"	.065"	<b>B9WWWW-G150P</b>	<b>B9WWWW-R150P</b>
2"	4.125"	2.062"	.065"	<b>B9WWWW-G200P</b>	<b>B9WWWW-R200P</b>
3"	5.187"	2.593"	.065"	<b>B9WWWW-G300P</b>	<b>B9WWWW-R300P</b>
4"	6.875"	3.437"	.083"	<b>B9WWWW-G400P</b>	<b>B9WWWW-R400P</b>

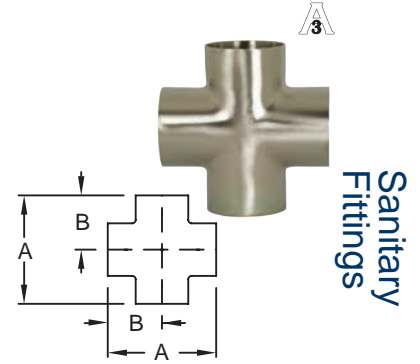

Sanitary Fittings

Miscellaneous Polished Weld Configurations

Laterals - B28WA

Tube OD	Dimensions			Wall Thickness	Polished ID/OD
	A	B	R		316L Stainless Steel Part #
1"	6.000"	1.000"	5.000"	.065"	<b>B28WA-R100P</b>
1½"	7.375"	1.188"	6.188"	.065"	<b>B28WA-R150P</b>
2"	8.750"	1.625"	7.125"	.065"	<b>B28WA-R200P</b>
2½"	10.000"	1.500"	8.500"	.065"	<b>B28WA-R250P</b>
3"	10.750"	1.875"	8.875"	.065"	<b>B28WA-R300P</b>
4"	12.812"	2.015"	10.750"	.083"	<b>B28WA-R400P</b>

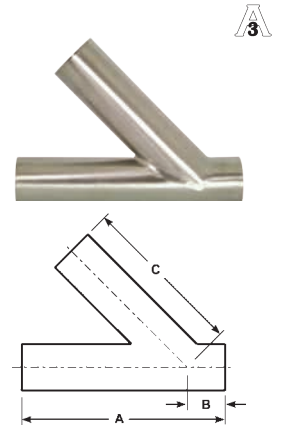

True Wyes - B28W

Tube OD	Dimensions		Wall Thickness	Polished ID/OD
	A	B		316L Stainless Steel Part #
1"	2.000"	2.438"	.065"	<b>B28W-R100P</b>
1½"	2.000"	2.438"	.065"	<b>B28W-R150P</b>
2"	2.625"	3.250"	.065"	<b>B28W-R200P</b>
2½"	3.370"	4.125"	.065"	<b>B28W-R250P</b>
3"	4.000"	4.875"	.065"	<b>B28W-R300P</b>
4"	5.375"	5.375"	.083"	<b>B28W-R400P</b>

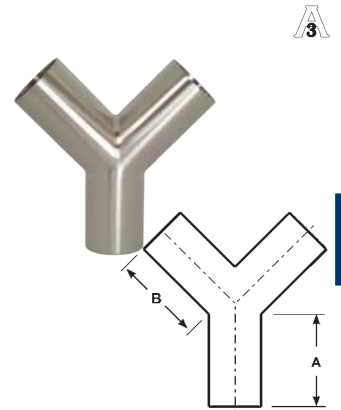

180° Return Bends - B2WUL

Feature:

- bends are standard 1.5 x tube diameter

Tube OD	Dimensions		Polished ID/OD
	A	B	316L Stainless Steel Part #
1"	3.000"	2.000"	<b>B2WUL-R100P</b>
1½"	4.500"	3.000"	<b>B2WUL-R150P</b>
2"	6.000"	4.000"	<b>B2WUL-R200P</b>
2½"	7.500"	5.000"	<b>B2WUL-R250P</b>
3"	9.000"	6.000"	<b>B2WUL-R300P</b>
4"	12.000"	8.000"	<b>B2WUL-R400P</b>

